

Driveway (Access) Permits
DRIVEWAYS

1. Access Permits are required for all approaches to County Roads or unorganized Township Roads. Permits are available at the Carlton County Transportation Department.
2. Any driveway or access constructed After February 11, 1992, will have a minimum 4:1 side slopes. Driveway side slope will be required to conform to the roadway design and may be increased based on current design standards. This includes driveways constructed by private individuals or under a county road construction project.
3. No retaining wall will be allowed in driveway construction.
4. If you access will impact wetlands, ([Zoning & Planning Wetlands Page](#)) you are responsible for contacting the [local wetland conservation act administrator](#) and applying for an exemption.
5. The Access Permit Application form and instruction sheet may be printed out from your computer, picked up at the address below, or mailed per your phone or e-mail request.

Carlton County Transportation
1630 County Road 61
Carlton, MN 55718
(218)384-9150
Transportation@co.carlton.mn.us

A completed application form and sketch may be submitted without payment. The Transportation Maintenance Superintendent will review your request and visit the site to determine acceptable construction details, culvert requirements and cost. You will then be notified of these things.

There is a \$250.00 deposit/fee required for a Driveway Access Permit. Sorry, no credit card payments accepted. Culverts may be purchased at cost from the Transportation Department. Prices vary by size. Transportation maintenance crew will deliver the culvert to access site within five business days after receipt of payment. Applicant is responsible for fill material, related earthwork and for requesting a final inspection within 30 days.

Upon satisfactory completion of the access, up to \$200 may be refunded. \$50 is retained as a permit fee. An additional \$50 per occurrence will be retained from the deposit whenever additional site inspections are needed to obtain compliance with the permit requirements.

ACCESS DRIVEWAY PERMIT APPLICATION INSTRUCTIONS

1. Complete upper portion of application form.
2. Draw a sketch of property. Show property lines and distance from nearest property line to proposed driveway access.
3. Return completed, signed application and sketch to the Transportation Office. (No money required until site is approved.)
4. Mark the access site with stake and ribbon, 20 feet apart and high enough to be seen from a pick-up truck on the road.
5. County Maintenance Superintendent will make a field review of marked site within 1-5 days of request.
6. Site inspection results and costs submitted to applicant.
7. Remit permit fee/deposit amount (and culvert cost-if any) to Transportation Department. Cash, money order or check only. Permit will be issued and work on access may begin. Culvert to be delivered within 5 days or as arranged. Fill material and labor provided by applicant.
8. Complete access work in right-of-way within 30 days and notify Transportation Department for final inspection. (Sites requiring the **removal** of an access shall be inspected again after the site has been restored to original condition.)
9. County will inspect completed work and either refund deposit or notify applicant of corrections necessary for acceptance.

NOTE: Wetland Conservation Act Provisions apply to all individual private property owners. Contact your local Planning & Zoning Department for further information. There are penalties for failure to comply.

APPLICATION FOR ACCESS DRIVEWAY PERMIT

County Road _____

Applicant Name _____ Property Owner (if not applicant) _____

Mailing Address (for deposit refund) _____ Property Address _____

City _____ State _____ Zip Code _____ Phone number(s) _____

Property located in the NE-NW-SE-SW Quarter of _____
(Sec-Twp-Rg)

_____ Miles/Yards N-S-E-W of _____
(Nearest intersecting road) on N-S-E-W side of road

Purpose of access: Why do you want to drive into this property? _____

Will structures be added to property? YES-NO Type: _____

Have you contacted Planning & Zoning about permit requirements, including WETLAND status? YES-NO-NEED INFO

Is there an existing access driveway to the property now? NO-YES (If yes, describe reason for second access request) _____

When will site be marked and ready for our review? Date: _____ Remarks _____

I-We, the undersigned, herewith make application for permission to construct the access driveway at the above location. Said driveway to be constructed to conform with the regulations of the Carlton County Transportation Department and to any special requirements and special provisions included in the permit. It is expressly understood that this permit is conditioned upon replacement or restoration of the highway to its original or to a satisfactory condition and that this permit is subject to the approval of local city or village authorities having joint supervision over said street or highway. _____

_____ Date _____ Applicant Signature _____

Office Use Only: **Carlton County Transportation Department**
1630 County Road 61, Carlton, MN 55718
Phone: (218)384-9150 Fax: (218)384-4089 Access Permit Number

ACCESS TYPE: Permanent Temporary Replacement

ACCESS SITE: Approved Denied Remarks: _____

No culvert needed Curb cut required _____

Culvert required _____ inch X _____ foot Culvert _____ band _____ apron(s)

By _____ on _____
\$ _____ Deposit/Fee paid on _____ \$ _____ Culvert costs paid on _____

(\$250.00 Deposit, \$200 refundable) \$ _____ Total Cost Due (Deposit/Fee + Culvert/Band/Apron)

Requested culvert delivery: _____ Delivered: _____ **Copy to Zoning Copy to Trans. Sup.**

Requested final inspection: _____ Completed access approved: _____ By: _____

Remarks: _____ Deposit Refunded: _____

ENTRANCE CONSTRUCTION DETAILS

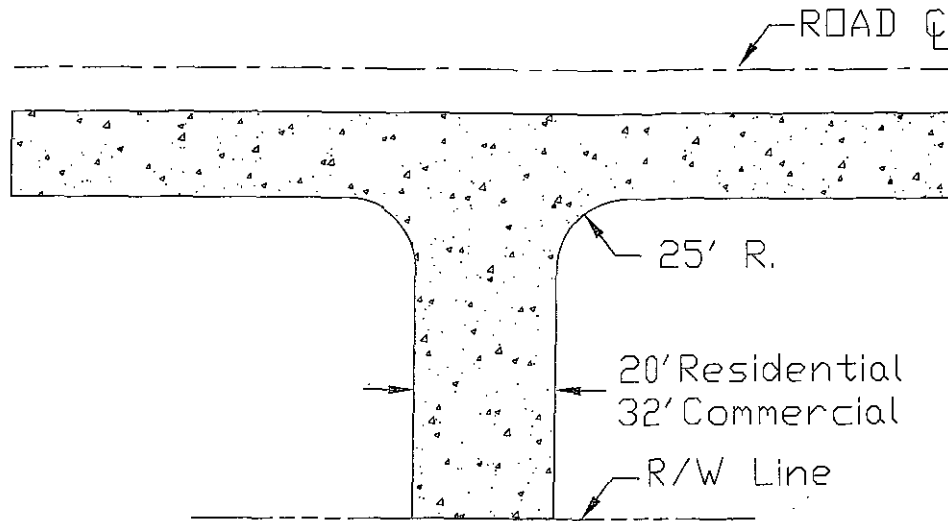

OVERHEAD VIEW

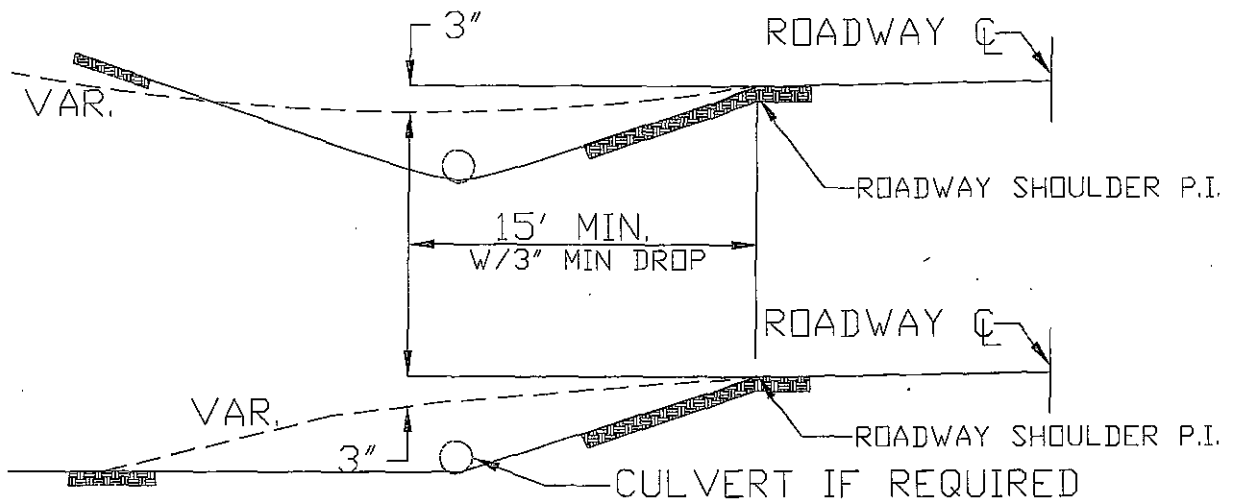

SIDE VIEW

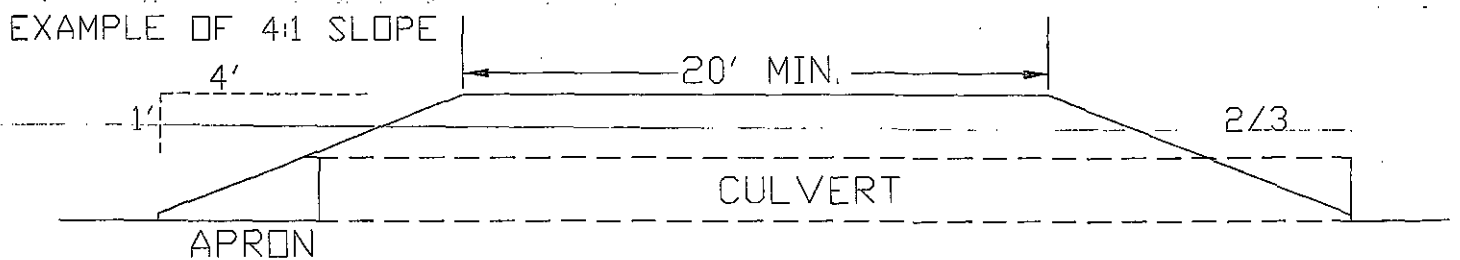

CROSS-SECTION

ENTRANCES
CARLTON COUNTY HIGHWAY DEPT
MINIMUM STANDARDS